

JUDGE ROSE BOYKO, Presiding.

Synopsis

1. The Appellant, Samir Adwan (Adwan), a teacher with the United Nations Relief and Works Agency for Palestine Refugees in the Near East (UNRWA) for 22 years, submitted a letter of resignation and shortly thereafter indicated that he wished to withdraw his letter of resignation and be reinstated. UNRWA had already filled his position and refused to reinstate him. Adwan appealed to the UNRWA Area Staff Joint Appeals Board (UNRWA JAB), but the Commissioner-General confirmed the decision. This Court holds that UNRWA had the discretion and authority not to reinstate the staff member as it had already filled his position before receiving his letter attempting to withdraw his resignation.

Facts and Procedure

2. By letter dated 28 September 2003, Adwan notified the Director of the Regional Education Programme, UNRWA/Syria, of his resignation “as [of] the 1st of October 2003 for private reasons”. The date stamped on the letter indicated that the UNRWA Personnel Section received it on 1 October 2003.

3. In a reply written in English and Arabic, the Field Personnel Officer and Deputy Field Administration Officer, Syria Field Office of UNRWA, advised Adwan as follows:

[Y]our resignation has been approved effective close of business on **30 September 2003**. *However, should you change your mind and wish to cancel your request for resignation, such request may be reviewed on its own merits and without any obligation on the part of the Agency only within 6 working days from the date you left Agency service.* (Bold and Italics in original)

The letter continued: “A Personnel Action Form will be issued in due course to establish your separation...” It is not clear when this letter was mailed to Adwan. The copy of the letter that was attached to the Respondent’s Answer provides no such information. But the copy that Adwan has provided bears a date stamp of 13 October 2003. According to Adwan, UNRWA dispatched the said letter on 13 October 2003, but backdated it to 5 October 2003.

4. On 7 October 2003, Adwan wrote the following to the Chief of the Field Education Programme in Syria:

I hope you would kindly reconsider rein

5. The next day, the Chief of the Fiel

to the completion with separate October 2003, the Field Personnel Officer wrote to Adwan and advised him that his requ

THE UNITED NATIONS APPEALS TRIBUNAL

UNRWA's credibility is thus called into question because the day stamp was rubbed out from the copy of the letter attached to the Respondent's Answer.

16. Adwan further argues that because it failed to respond to his letters, UNRWA cannot now accuse him of not observing the time limits. Before UNRWA wrote to accept his resignation, Adwan had the right to withdraw his resignation. After he had sent repeated reminders to the UNRWA Administration, Adwan was verbally told to wait. Although UNRWA left open the possibility of Adwan withdrawing his resignation, but did not wait until the end of the six-day grace period to fill Adwan's post, especially since there were many vacant teacher posts that UNRWA could have used to accommodate Adwan.

17. On the merits of the reinstatement issue on appeal, UNRWA's position is that the UNRWA JAB did not err when it denied the appeal. UNRWA submits that there was no appealable decision presented to the JAB. It was Adwan who unilaterally decided to resign when he sent a notice of resignation on 28 September 2003 and ceased to report to work after 30 September 2003. The decision to resign was Adwan's and his alone. The UNRWA Administration did not take any decision in its wake that did not observe the terms of his appointment. It should be noted that no right of rescission exists in either Adwan's conditions of appointment or the Area Staff Regulations and Rules. There was no obligation for UNRWA to accept Adwan's request to withdraw his resignation.

18. The UNRWA Administration received Adwan's request to withdraw his resignation, but fulfilled all its obligations towards him in the proper exercise of its discretionary authority. UNRWA was entitled to rely on the voluntary and unilateral actions initiated by Adwan in the organization and management of its human resources. To permit otherwise would deny the Agency finality with respect to those decisions, rendering unworkable the operations of the Agency in the delivery of its mandate.

19. As Adwan resigned from his teacher position in the middle of a school year on a very short notice, the Agency was obliged to act expeditiously to fill the vacancy and replace him. The UNRWA Administration wrote and sent the letters dated 5 October and 12 October 2003 respectively. It did not alter the dates on the letters in any manner, or delayed their dispatch.

Considerations

20. The first issue in this appeal is whethe

THE UNITED NATIONS APPEALS TRIBUNAL

Case No. 2010-025



Judge Boyko, Presiding



Judge Painter

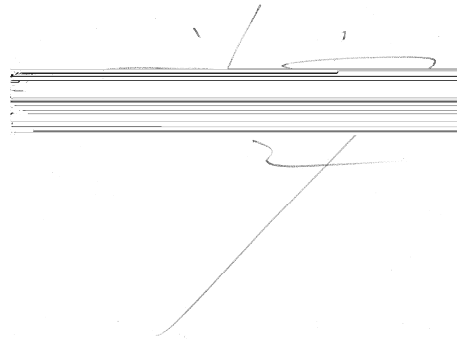

Judge Simón

Dated this 30th day of March 2010 in Geneva, Switzerland.

Original: English

Entered in the Register on this 26th day of April 2010 in New York, United States.



Weicheng Lin, Registrar, UNAT